

# INSTALLATION INSTRUCTIONS

## for ARRAY SPLICE CASSETTES

### 265-CAS10 SERIES

### MOUNTING IN CONNECTING HARDWARE

Affix base ① using two sets of screws and nuts ② provided with cassette to connecting hardware with desired orientation.

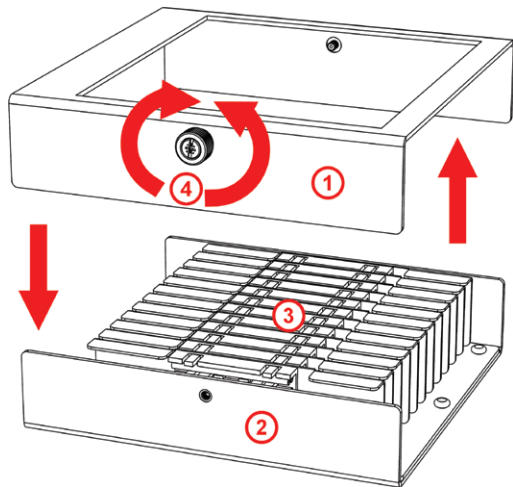
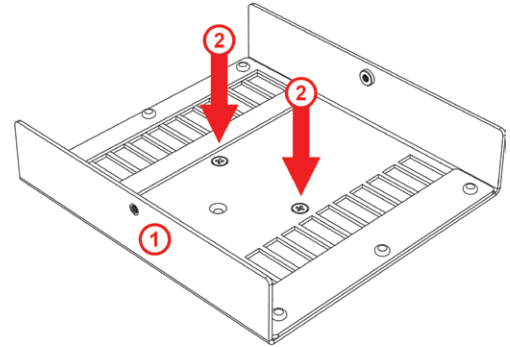

### COVER PLACEMENT/REMOVAL

Cover placement:  
put cover ① over base ②, adjust cartridge top flanges ③ in cover's rectangular opening, and tighten two captive screws ④.  
Cover removal:  
loosen two captive screws ④ and remove cover ①.

### CARTRIDGE INSERTION/REMOVAL

Cartridge insertion:  
insert cartridge "legs" ① in corresponding slots in base's bottom grid ② and slide cartridge forward until locked in place ③.  
Cartridge removal:  
push cartridge out of its slot and pull out.

